

# COLOURBOND NAILSTRIP FIXING INSTRUCTIONS

## TYPICAL PANEL TURN-DOWN

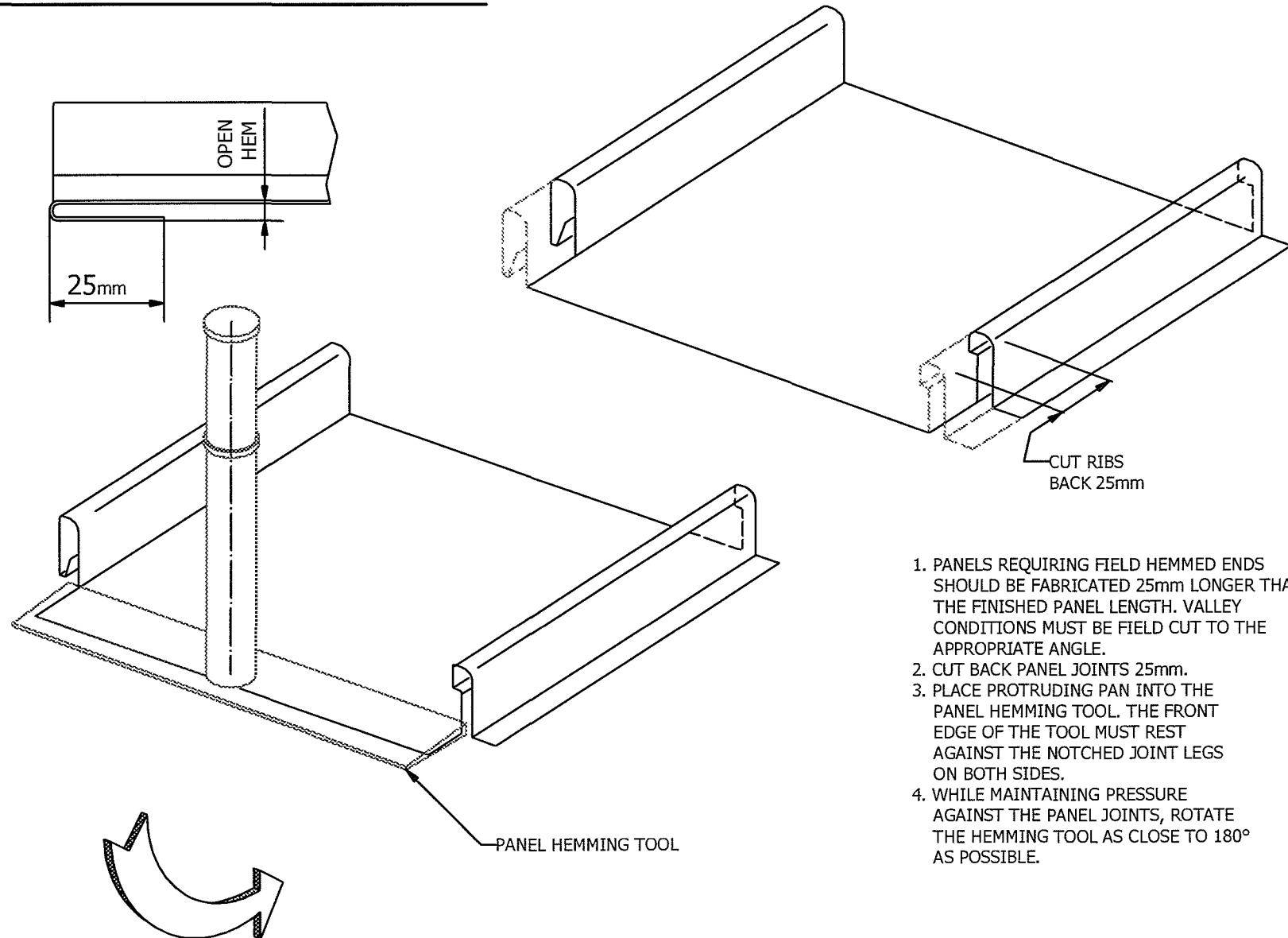

1. PANELS REQUIRING FIELD HEMMED ENDS SHOULD BE FABRICATED 25mm LONGER THAN THE FINISHED PANEL LENGTH. VALLEY CONDITIONS MUST BE FIELD CUT TO THE APPROPRIATE ANGLE.
2. CUT BACK PANEL JOINTS 25mm.
3. PLACE PROTRUDING PAN INTO THE PANEL HEMMING TOOL. THE FRONT EDGE OF THE TOOL MUST REST AGAINST THE NOTCHED JOINT LEGS ON BOTH SIDES.
4. WHILE MAINTAINING PRESSURE AGAINST THE PANEL JOINTS, ROTATE THE HEMMING TOOL AS CLOSE TO 180° AS POSSIBLE.