

Long Length Roofing Solutions.

Step joints are now a thing of the past.

Why are step joints incorporated in roof designs?

The answer: Before Fielders long length roofing solutions there was no other option.

Step joints serve no function in a concealed fixed roof and are a legacy of manufacturers' inability to transport sheets longer than 29 metres. Step joints can be the 'weakest link' in an otherwise sound roof. They allow for the build up of debris and constitute as an unwashed area that are not covered by the BHP Warranty.

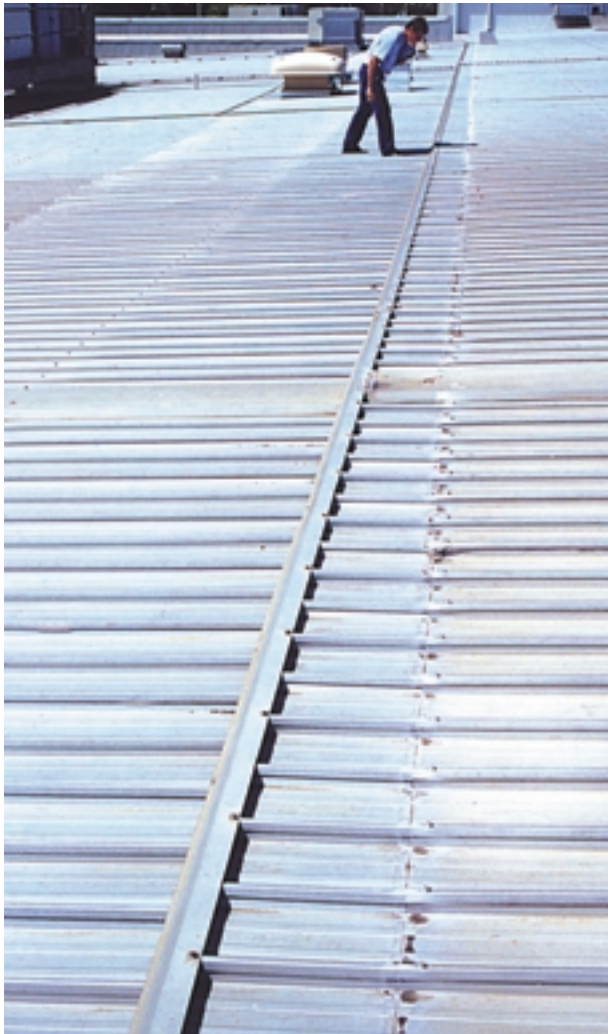

Fielders Long Length Roofing Solutions.

The success and superior performance of Fielders long length roofing solutions has been well documented since we first introduced on-site mobile rollforming in Australia. Fielders have successfully supplied sheet lengths of up to 84 metres in Australia, eliminating the need for unsightly step joints.

Developers, builders and roofers have now experienced the economical and functional benefits of long length sheeting which has led to its rising popularity. As such, the number of Fielders Mobile Mills has increased to 6, and rolls products like HiKlip®, WideKlip®, and KingKlip®.

Fielders range of concealed fixed, long length roofing solutions is designed to accommodate the thermal movement of the deck and components as well as provide superior resistance to high wind loads.



For more information contact Fielders on Freecall: 1800 182 255
Email: info@fielders.com.au • Web: www.fielders.com.au
Adelaide • Melbourne • Sydney • Perth • Darwin • Mildura



OFFERING SOLUTIONS FOR TOMORROW

What do you get with a Fielders long length roofing solution?

- No leaking screw holes
- Fielders unique 20 Year Post installation Watertight Guarantee
- No unsightly and Costly Step Joints

Long length roof sheeting saves on unnecessary material and labour.

Remove the step - remove the leaks and the cost!

With a long length roofing solution you also remove the cost of the associated material and labour involved in creating a step joint.

- Saving from removing the extra row of purlins and cleats - \$19.50 per metre
- Saving from removing the step joint flashing - \$10 per metre
- Saving due to less roof sheeting required by removing overlap - \$3.90 per metre

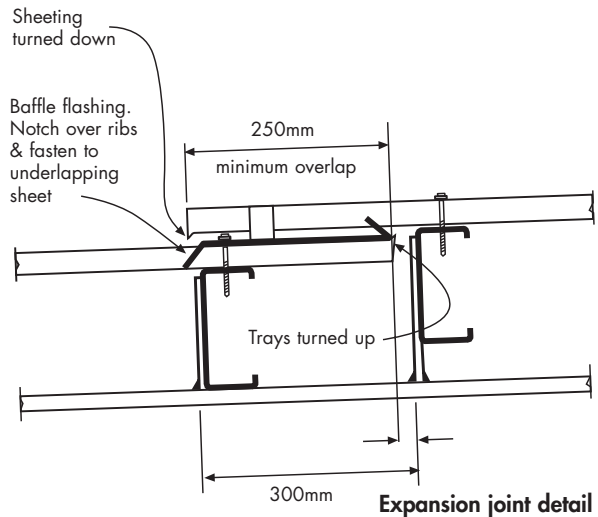

Long Length roofing removes a \$33 per metre step joint cost!

Getting it right ...the second time

The demand for long length roofing solutions has led to Fielders pioneering reroofing applications without step joints.

Fielders approved contractors can successfully re roof your commercial building and eliminate step joints with a long length solution without the need to change the existing structure.

