

Cyclonic Performance of S-Rib™ Corrugated

Fielders have undertaken cyclonic testing of S-Rib™ in accordance with the Low-High-Low cyclonic testing method in the BCA.

The cyclonic wind load capacities for S-Rib™ roofing profile is shown in Table 1 below.

S-Rib™ Corrugated Cyclonic Wind Load Capacity – Strength Limit State (kPa)												
Span (mm)	0.42 mm BMT				0.48 mm BMT				0.60 mm BMT			
	Single Span	Double Span	Multiple Spans		Single Span	Double Span	Multiple Spans		Single Span	Double Span	Multiple Spans	
			End	Internal			End	Internal			End	Internal
600	16.12	11.01	8.92		17.30	11.92	9.71		18.89	12.51		
900	10.62	5.60	5.68	7.53	11.27	6.16	6.29	8.25	12.26	6.78	8.91	
1200	7.18	3.47	3.61	5.23	7.52	3.83	4.07	5.81	8.25	4.17	3.67	8.28
1500	5.80	2.35	2.30	3.63	6.04	2.58	2.64	4.09	6.24	2.76	3.99	5.75
1800				2.52				2.88			3.00	4.26
2100												3.31

Table 1 – S-Rib™ wind load capacity – strength limit state design – Cyclonic.

The allowable roof spans for the S-Rib™ Corrugated roofing profile in Regions C and D are shown in Tables 2 and 3.

The allowable spans have been determined from tests carried out in accordance with AS4040.0-1992, AS 1170.2-2002 and the Building Code of Australia (BCA) 2008 Specification B1.2 for the design of buildings in cyclonic areas.

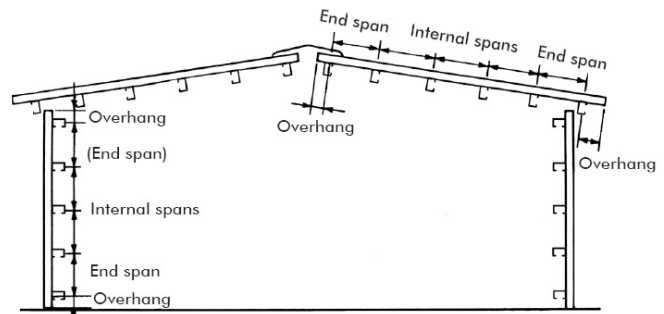

Figure 1 – Span locations.

Design parameters for Tables 2 and 3 are shown below:

- $P_{o,r} = 1:500$
- $V_r = 66 \text{ m/s}$
- $M_d = 1.00$
- $F_c = 1.05$
- $M_s = 1.00$
- $M_l = 1.00$
- $C_{p,i} = 0.70$
- $C_{p,e} = -0.90$
- $K_l = 1.5$ for Area F
- $K_l = 2.0$ for Area G

The local pressure factors (K_l) are shown in Figure 2. Local pressure factors are not applicable at the ridge where the roof pitch is less than 10° . The value of 'a' is the minimum of 0.2 breadth, 0.2 width or the height.

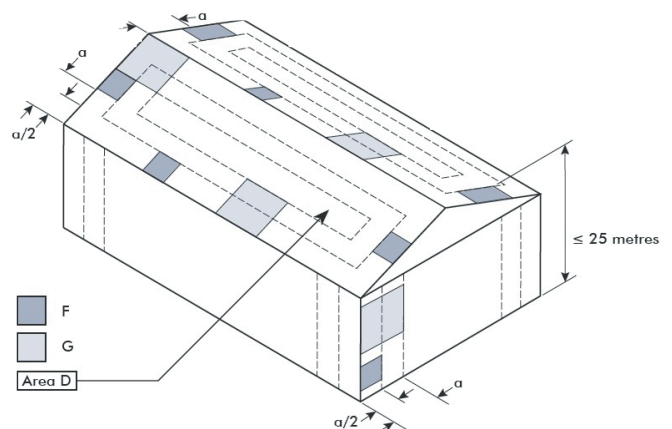

Figure 2 – Local pressure factors.

S-Rib™ Corrugated Allowable Roof Spans (mm) in Region C Cyclonic – for building height ≤ 5.0 m

Terrain Category	Roof Area Notation & Uplift (kPa)**	0.42 mm BMT				0.48 mm BMT				0.60 mm BMT			
		Single	Double	Multiple Spans		Single	Double	Multiple Spans		Single	Double	Multiple Spans	
				End	Internal			End	Internal			End	Internal
1 & 2	D-4.18	1930	1060	1100	1380	2040	1130	1180	1480	2010	1200	1460	1820
	F-5.35	1560	920	940	1180	1650	970	1010	1270	1670	1030	1240	1570
	G-6.53	1310	830	810	1020	1340	870	870	1100	1440	920	1100	1390
2.5	D-3.54	2230	1180	1210	1520	2350	1260	1300	1620	2280	1320	1620	2020
	F-4.54	1800	1010	1050	1320	1900	1070	1120	1410	1890	1140	1380	1730
	G-5.54	1510	910	910	1150	1600	960	990	1240	1630	1010	1220	1530

S-Rib™ Corrugated Allowable Roof Spans (mm) in Region D Cyclonic – for building height ≤ 5.0 m

Terrain Category	Roof Area Notation & Uplift (kPa)**	0.42 mm BMT				0.48 mm BMT				0.60 mm BMT			
		Single	Double	Multiple Spans		Single	Double	Multiple Spans		Single	Double	Multiple Spans	
				End	Internal			End	Internal			End	Internal
1 & 2	D-6.66	1315	840	810	1015	1375	875	870	1095	1435	915	1110	1390
	F-8.54	1080	735	635	770	1120	775	705	865	1180	810	935	1170
	G-10.41	910	635	460	525	970	680	540	635	1040	710	760	945
2.5	D-5.65	1535	895	905	1145	1535	925	985	1230	1590	1030	1205	1520
	F-7.24	1195	810	755	940	1255	845	815	1025	1350	875	1055	1325
	G-8.83	1055	720	619	730	1095	760	675	830	1155	795	905	1135

Table 2 – S-Rib™ Corrugated maximum allowable roof spans for building heights ≤ 5.0 m.

S-Rib™ Corrugated Maximum Allowable Roof Spans (mm) in Region C Cyclonic – for 5.0 m > building height ≤ 10.0 m

Terrain Category	Roof Area Notation & Uplift (kPa)**	0.42 mm BMT				0.48 mm BMT				0.60 mm BMT			
		Single	Double	Multiple Spans		Single	Double	Multiple Spans		Single	Double	Multiple Spans	
				End	Internal			End	Internal			End	Internal
1 & 2	D-4.18	1770	1000	1030	1300	1870	1060	1110	1390	1860	1130	1360	1710
	F-5.35	1430	870	870	1100	1510	920	940	1180	1550	970	1160	1470
	G-6.53	1200	780	740	930	1280	820	800	1010	1330	870	1030	1300
2.5	D-3.54	1950	1070	1110	1390	2060	1140	1190	1490	2030	1210	1470	1830
	F-4.54	1570	930	940	1190	1660	980	1020	1280	1680	1040	1250	1570
	G-5.54	1330	830	810	1020	1410	880	880	1110	1450	930	1100	1400

S-Rib™ Corrugated Maximum Allowable Roof Spans (mm) in Region D Cyclonic – for 5.0 m > building height ≤ 10.0 m

Terrain Category	Roof Area Notation & Uplift (kPa)**	0.42 mm BMT				0.48 mm BMT				0.60 mm BMT			
		Single	Double	Multiple Spans		Single Span	Double Span	Multiple Spans		Single Span	Double Span	Multiple Spans	
				End	Internal			End	Internal			End	Internal
1 & 2	D-7.38	1155	800	745	920	1230	835	805	1005	1330	870	1040	1305
	F-9.46	1000	685	550	650	1045	730	620	750	1110	760	850	1060
	G-11.54	850	570	355	375	885	620	440	495	955	650	660	815
2.5	D-6.59	1330	845	815	1025	1340	880	875	1105	1450	920	1115	1400
	F-8.45	1090	740	645	780	1125	780	710	875	1185	815	945	1180
	G-10.30	930	640	470	540	980	685	550	650	1045	715	770	950

Table 3 – S-Rib™ Corrugated maximum allowable roof spans for 5.0 m > building height ≤ 10.0 m.

Note to Table 2 and 3:

** Pressure is total ultimate value

For more information contact Fielders on Freecall: 1800 182 255

Email: info@fielders.com.au • Web: www.fielders.com.au

Adelaide • Melbourne • Sydney • Perth • Brisbane • Darwin

JUNE 2010



FINISH ON TOP WITH FIELDERS

Fixing of Cladding

Fasteners must be selected to match the life expectancy of the cladding material. Recommendations from fastener manufacturers should be sought. Only fasteners complying with AS 3566:2002 and those that are compatible with the roofing material should be used for its fastening.

All fasteners used externally should be fitted with an EPDM seal. Do not use punches to form fastener holes. Fasteners are fixed at **alternate crests** of the S-Rib™ Corrugated roof sheeting.

S-Rib™ Pierce Fixing – Cyclonic		
Fixing Supports	Crest Fixing	Side Lap Fixing
Steel 1.5 mm	14-10x42mm Metal Tek's head Corri-Lok cyclone assembly	10 x 16mm Neo Tek's hex head

For further information on the S-Rib™ Corrugated roofing profile, including installation procedures, refer to Specifying Fielders – Roofing & Walling manual.

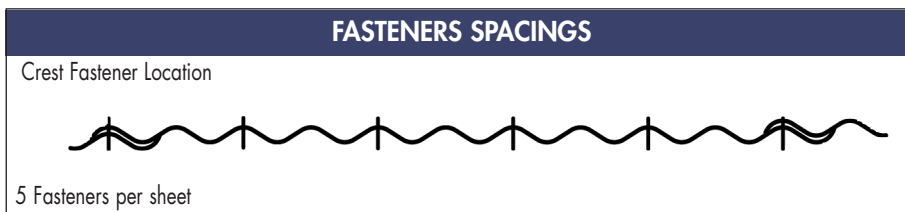

CREST FIXING DETAILS

1. INTERNAL & EDGE SUPPORTS

TIGHTEN SCREW SUCH THAT GASKET IS FIRMLY CLAMPED AND A LEAKPROOF JOINT OBTAINED.

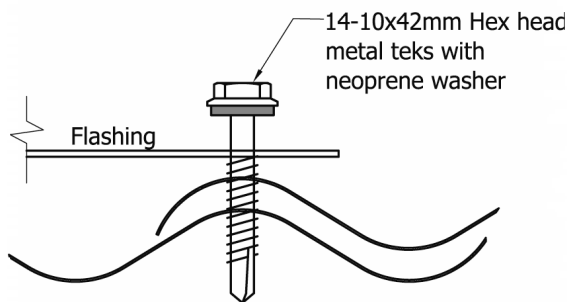
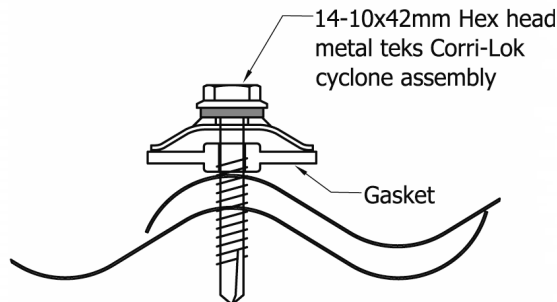

2. RIDGE & HIP SUPPORTS

DRIVE SCREW UNTIL DEFORMATION IS JUST VISIBLE AT CREST OF CORRUGATION.

Figure 3 – Fixing Details.

References:

Australian Building Codes Board 2008, *Building Code of Australia*, Australian Building Codes Board, Australia
 Standards Australia 2002, AS 1170.2 – *Structural design actions part 2: wind actions*, Standards Australia, Sydney, Australia
 Standards Australia 2002, AS 3566 – *Self-drilling screws for the building and construction industries*, Standards Australia, Sydney, Australia
 Standards Australia 1999, AS4040.0 - *Methods of testing sheet roof and wall cladding* – Introductions, list of methods and general requirements.

Disclaimer:

This data sheet updates and amends section 2.15 from Specifying Fielders – Roofing and Walling Edition 2 2008.

Care has been taken to ensure that the information herein is accurate, but Fielders Australia and its agents do not accept responsibility for errors due to misinterpretation of the information by the user. Standard Warranty imposed by statute law only applies with all other conditions, warranties and representations on the part of Fielders expressly excluded. Damages for breach of any warranty shall not extend to any consequential damages whatsoever.

For more information contact Fielders on Freecall: 1800 182 255

Email: info@fielders.com.au • Web: www.fielders.com.au

Adelaide • Melbourne • Sydney • Perth • Brisbane • Darwin

JUNE 2010



FINISH ON TOP WITH FIELDERS