

S-Rib Corrugated



Tough and Timeless in Every Sense



FINISH ON TOP WITH FIELDERS STEEL ROOFING

Fielders S-Rib Corrugated.

Tough. And timeless in every sense.

A reliable product that stands the test of time, Fielders S-Rib Corrugated can be used as either a roofing or a walling product. This profile can reflect a modern or traditional design, depending on the application. Complimented by Fielders' range of heritage products, a beautifully authentic restoration can also be achieved.

Wide range of materials and thickness

Fielders offer a unique range of materials and gauges. Bluescope's Zinalume® and Colorbond® products form the core base of Fielders Corrugated S-Rib offer. Colorbond® Ultra and Metallic is also readily available. Gauges vary according to product and application, but range from 0.35BMT for fencing and walling only, through to 0.42BMT and 0.48BMT for roofing and 0.60BMT 'soft feed' typically for bullnose and curved roofing applications. For a different environmental and aesthetic application, Colorcoat HPS200® is offered exclusively by Fielders in Australia. Fully imported from Corus in the UK its durability and distinctive Scintilla finish sets a different tone in the Australian marketplace. Available in 0.50BMT HPS200® is ideally suited for both the domestic and commercial market, particularly suited to marine environments.





Barrel Rolling. Resurrecting technology. Re-creating history.

Corrugated S-Rib is featured as the roof finish of choice for many Australian homes. Modern roll forming methods allow millions of metres to be rolled throughout Australia every year. However, the foundation of this product lies in a process used in the early parts of the 20th century known as "Barrel Rolling".

Our beautifully restored 75 year old barrel press rolls steel to create authentic, deep corrugations (19mm – 3/4"), compared with 16mm for standard roll formers, and a cover of approx 690mm. This authentically profiled product is called "3/4" corrugated" and is available in short sheets up to 10 feet (3.05m) in length, to perfectly match those on century-old buildings. The Sydney Harbour Trust has preserved the heritage buildings on Cockatoo Island and the North Head Artillery School, using Fielders Barrel Rolled Heritage Galv.

An Extra Ounce of Protection.

Back in 1900 when Fielders was first established, galvanised roofing came in two weights: light Z275 (one ounce per square foot) and heavy Z600 (two ounces per square foot).

The quality roofs that survived the last century were generally treated with the heavier, longer-lasting two-ounce coating, which was double-smelted for durability. But as time passed, compromises were made as builders economised with the Z450 one and a half ounce product that simply didn't take the ravages of time as well. Fielders, for once, has taken a step back in time and reintroduced the traditional heavy coated Galvanised Z600 steel. Whether **Barrel Rolled** or rolled as standard **Corrugated S-Rib**, Fielders offer an extra ounce of protection.

A good old-fashioned guarantee

Fielders stands alone as the only company in Australia making heritage galvanised roofing backed with an anti-corrosion guarantee of up to 15 years*.

*subject to conditions



S-Rib™ Corrugated

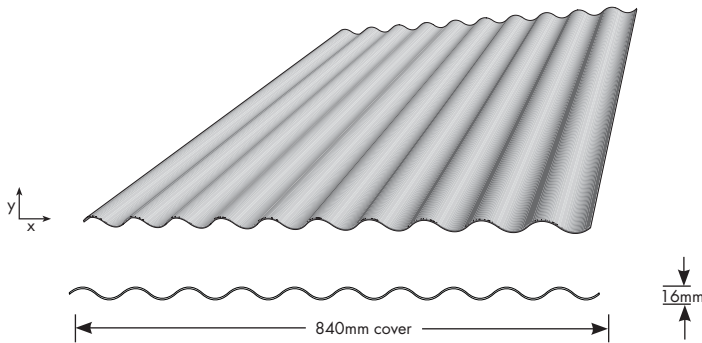

S-Rib™ Corrugated Material Specifications						
Property		0.35 BMT	0.42 BMT	0.48 BMT	0.60 BMT	Notes
Total Coated Thickness		0.40	0.47	0.53	0.65	TCT
Mass / Unit Length (kg/m)	ZINCALUME®	2.75	3.30	3.70	4.70	1000 / (m/Tonne)
	COLORBOND®	2.80	3.36	3.77	4.78	
Mass / Unit Area (kg/m²)	ZINCALUME®	3.60	4.34	4.87	6.18	1000 / (m Mass/profile width)
	COLORBOND®	3.68	4.42	4.96	6.29	
2 nd moment of area about principal axis (10 ³ mm ⁴)	I _x	11	14	15	19	
	I _y	19510	23420	26760	33450	
Section modulus about principal axis (10 ³ mm ³)	Z _x	1	2	2	2	
	Z _y	47	56	64	80	
Warping Constant (10 ⁹ mm ⁶)	I _w	1	1	1	1	
Torsion Constant (mm ⁴)	J	13	23	35	68	
Minimum Yield Strength		G550	G550	G550	G300	Base Steel Designation
Coating Class		AZ150 (150g/m²) AZ200 (Ultra) Z450 (Galvanised) Z600 (Heritage Galvanised)				Minimum Coating g/m² of Zinc - Aluminium
Coverage (mm)		762				
Tolerance		Sheet Length ±7mm Cover Width ±4mm				
Thermal Expansion		2.9mm average per 5m at 50° C change				

Table 2.15.A S-Rib™ Corrugated Material Specifications

Rainfall Capacity

For further information, please refer to sections 4.2 'Rainfall Intensity' and 4.3 'Water Carrying Capacity and Rainwater Run-Off'.

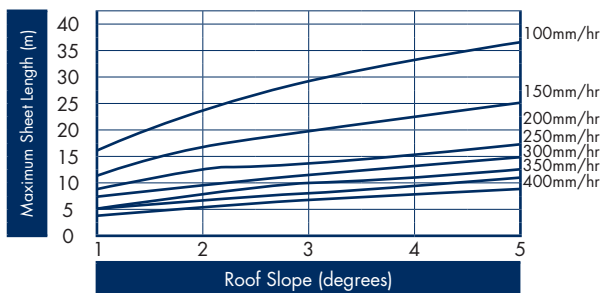

Figure 2.15.A S-Rib™ Corrugated Rainfall Capacity (mm/hr)

1. S-Rib Corrugated is manufactured to AS 1397 and AS 2728 Cat. 3. It is to be installed in accordance with AS 1445, AS 1562, and HB39.
2. The sectional properties are theoretical values per sheet width. These properties are gross values only.

Note: Minimum recommended slope is 5°. Sheet lengths greater than 24m are not recommended due to thermal expansion and contraction.

S-Rib™ Corrugated Max Sheet Length (m)

Roof Slope (degrees)	Rainfall Capacity (mm/hr)						
	100	150	200	250	300	350	400
1	-	-	-	-	-	-	-
2	-	-	-	-	-	-	-
3	-	-	-	-	-	-	-
4	-	-	-	-	-	-	-
5	37	25	18	15	12	11	9

Table 2.15.B S-Rib™ Corrugated Maximum Sheet Length (m)

Load Span Tables

The allowable spans have been determined from tests carried out in accordance with the following Australian Standards (wind load available by region): AS 1562.1 :1992, "Design and installation of sheet roof and wall cladding - Metal" and AS 4040:1992, "Methods of testing sheet roof and wall cladding".

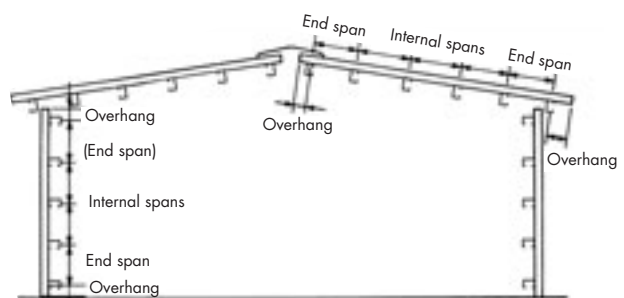

Figure 2.15 .B End Spans, Internal Spans and Overhangs

Maximum Recommended Span* (mm)
S-Rib™ Corrugated Non Cyclonic

Span Type	0.35 BMT		0.42 BMT		0.48 BMT		0.60 BMT	
	Roof	Wall	Roof	Wall	Roof	Wall	Roof	Wall
End Span	N/A	1200	900	1350	1200	1800	900	1350
Internal Span	N/A	1600	1200	1800	1600	2400	1200	1800
Unstiffened Overhang	N/A	N/A	200	N/A	250	N/A	200	300
Stiffened Overhang	N/A	N/A	300	N/A	350	N/A	300	300

Table 2.15.C S-Rib™ Corrugated Maximum Recommended Span - Non Cyclonic

S-Rib™ Corrugated Pierce Fixing - Non Cyclonic

Fixing Supports	Crest Fixing	Valley Fixing (Wall only)	Side Lap Fixing
Steel 1.0 to 3.5mm	12-14x35mm Metal Tek's hexagon head with seal	10-16x16mm Metal Tek's hexagon head with seal	10-16x16mm hexagon head Tek's screws with seal
Timber Hardwood	M6-11x50mm RoofZips hexagon head with HiGrip & seal	M6-11x25mm RoofZips hexagon head with seal	
Timber Softwood	M6-11x50mm RoofZips hexagon head with HiGrip & seal	M6-11x25mm RoofZips hexagon head with seal	
Metal Battens (0.55 to 1.0mm)	M6-11x50mm RoofZips hexagon head with HiGrip & seal	15-15x25mm Metal Batten Tek's hexagon head with seal	

Table 2.15.D S-Rib™ Corrugated Pierce Fixing - Non Cyclonic
Cyclonic data refers to Fielders fact file FFFR.2.2

Pierce Pierce Fixing

Fasteners must be selected to match the life expectancy of the cladding material. Recommendations from fastener manufacturers should be sought.

Only fasteners complying with AS 3566:2002 and those that are compatible with the roofing material should be used for its fastening.

Notes: All fasteners used externally should be fitted with an EPDM seal (washer). Do not use punches to form fastener holes.

Fastener Spacings - Non Cyclonic

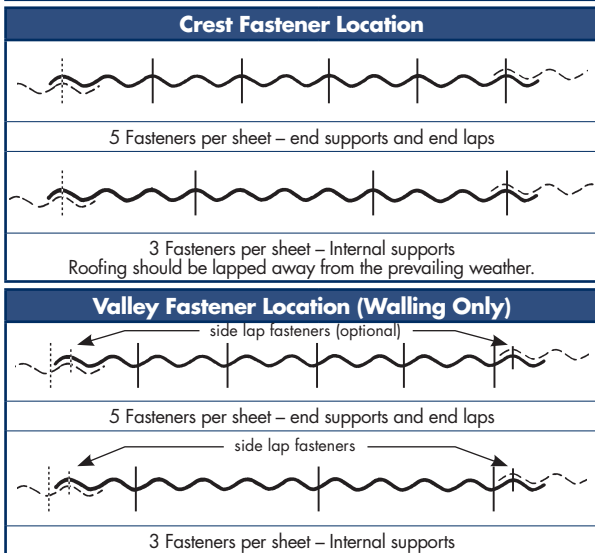

Table 2.15.F S-Rib™ Corrugated Fastener Spacings - Non Cyclonic

S-Rib™ Corrugated Installation Procedure

For installation procedures see section 4.7 "Typical Pierce Fix Installation Guide". For general handling instructions refer to section 5.0 'Maintenance and Care'.

Side Lap Fixing

It may be necessary to use side lap fasteners at mid spans when using S-Rib at maximum spans. These will help to hold the sheet laps firmly in place and maintain a weather-proof joint.

Turning of Roof Sheeting Ends

Refer to section 4.8 "Flashings, Cappings & Ends of Sheets" Specifying Fielders Manual.

Curving S-Rib™ Corrugated

For details regarding spring and smooth curving of S-Rib sheets, please see section 4.5 "Curving of Steel Decks" Specifying Fielders Manual.

Curving quality corrugated is manufactured from G300 substrate (0.60 BMT). It is consequently more ductile, enabling specialist tradesmen using precision curving machines to form sheets to traditional heritage shapes and challenging architectural details down to radii as tight as 450mm. Fielders has a dedicated roll forming machine for G300 thus avoiding any inconsistency arising out of changing over from G550 Hi-tensile coil.

AQUABLOK™ System

The AQUABLOK system utilises an anti-capillary gap that prevents water from seeping into roofing joints.

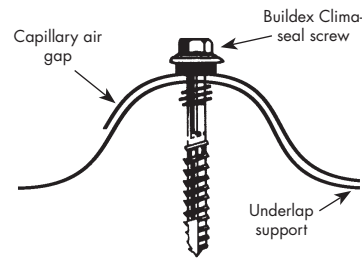

Figure 2.15.C AQUABLOK™ System

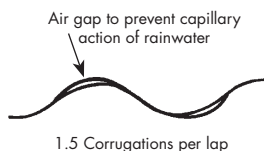

Figure 2.15.C Corrugation Laps

* For cyclonic data - refer Fielders Fact File R.2.2
www.fielders.com.au

Curving Orders

When ordering curved sheets, please state the following:

Zincalume	Sheets
Colorbond	Sheets
Color	Sheets
Direction of laying (facing roof)	
Left to right	Sheets
Right to Left	Sheets
Overall Length of Sheet (Allow 50mm into Gutters)	mm

Bullnosed

A	Radius (minimum 500mm)	mm
B	Pitch or fall	mm
D	Wall to outside fascia	mm
E	Straight length	mm
H	Height	mm

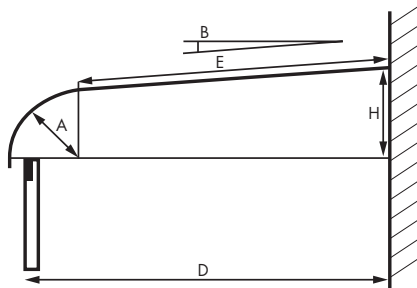

Figure 2.15.D Bullnosed Dimensions

Concave

D	Wall to outside fascia	mm
H	Height	mm
X	Dip from Straight Line	mm

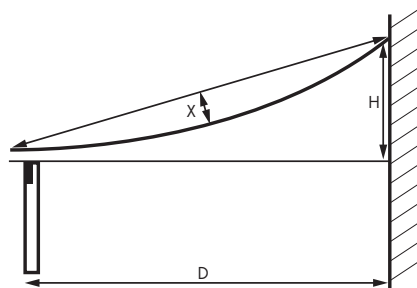

Figure 2.15.E Concave Dimensions

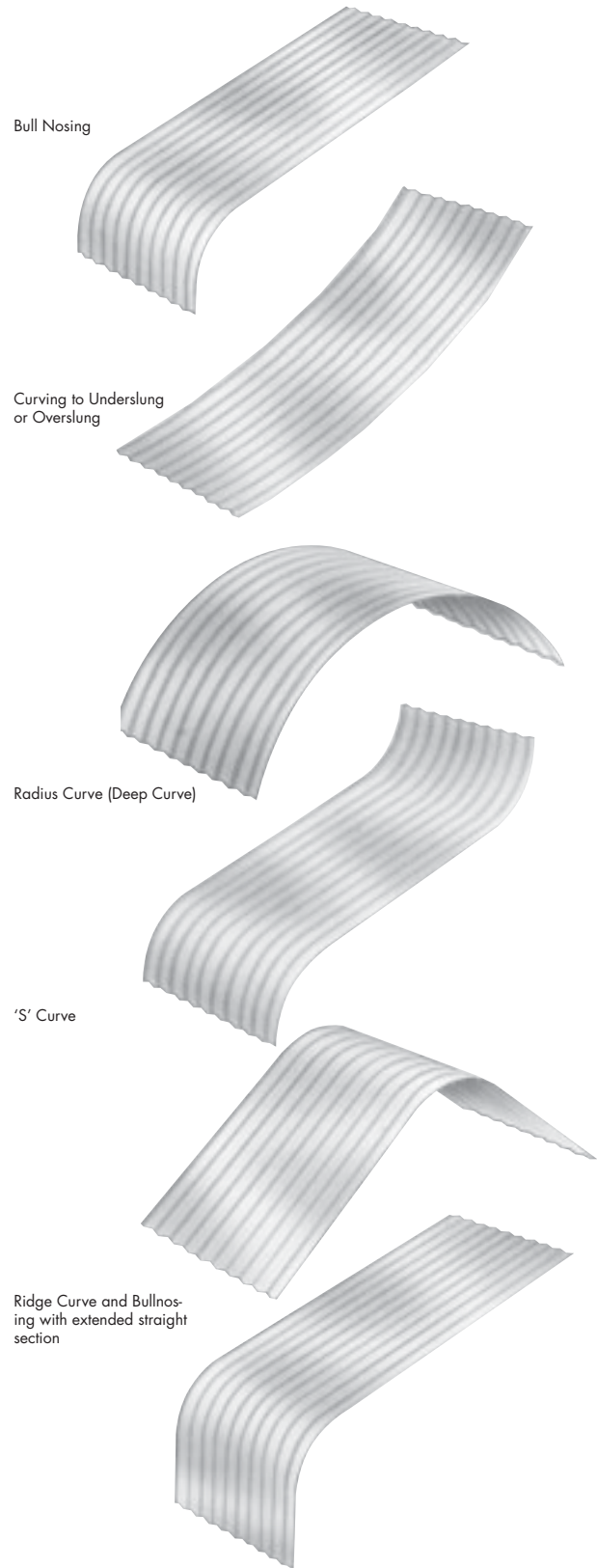

Figure 2.15.F Typical Curves

* HPS200® is a registered Trademark of Corus



FINISH ON TOP WITH FIELDERS STEEL ROOFING

Phone Fielders First 1800 182 255 www.fielders.com.au

ADELAIDE · MELBOURNE · SYDNEY · PERTH · BRISBANE · DARWIN