

CERTIFIED BY  
INDEPENDENT ENGINEERS

# FIELDERS Expa Tread™ walkway system

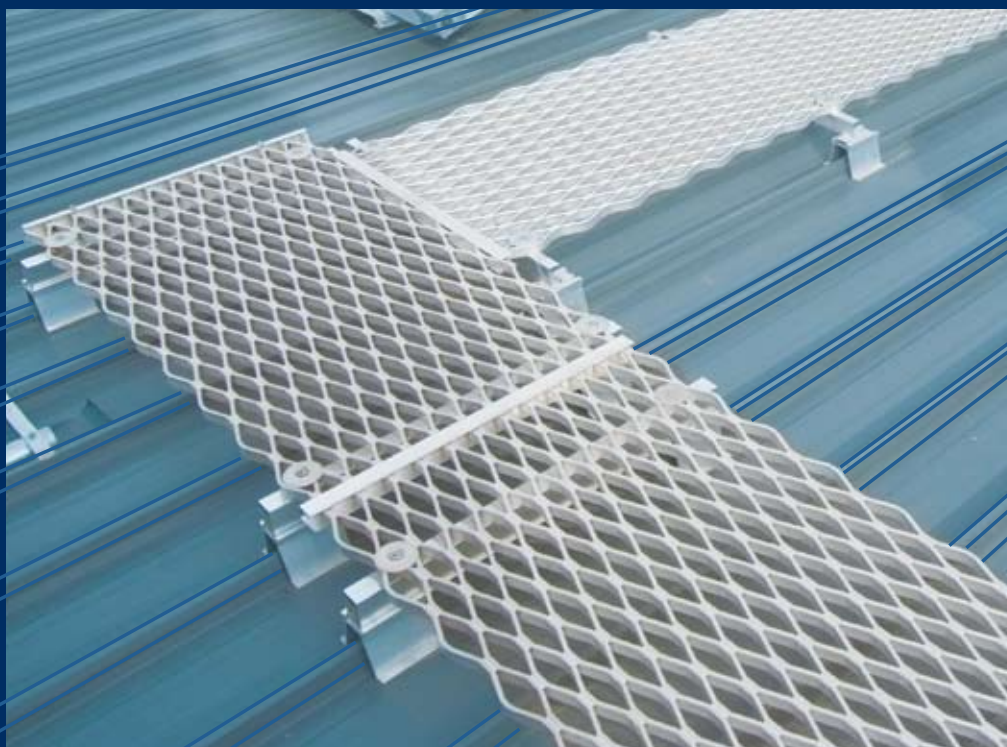

**Stick to the standards  
- without screwing up your roof.**



FINISH ON TOP WITH FIELDERS STEEL ROOFING

CERTIFIED BY  
INDEPENDENT ENGINEERS

# LIGHTER. STRONGER. NO CORROSION. NO DRILLING.

## Step up to a patented walkway system with all the answers.

### Fielders Expa-Tread™

Traditional roofing walkway systems demand that you tread a fine line. Risking damage to the roof by foot traffic and mechanical services installations, or open the door to leaks and potential corrosion by screwing a steel walkway system.

## Enter Fielders Expa-Tread™ - the one patented system with all the answers.

### No drilling means no leaks.

In a "world first" application, Fielders Expa-Tread™ utilises leading edge industrial adhesive technology that delivers secure, rigid fixing with no drilling at all. The fitting method also allows for thermal contraction and expansion of the roofing sheets through extremes of temperature without any collateral damage. Fielders Expa-Tread™ walkway system ensures compliance with Fielders Watertight 20 year no-leaks Guarantee for concealed fix roofing.\*

### Less weight, no corrosion.

Fielders Expa-Tread™ components are manufactured from aluminium; strong, much lighter than steel, and no corrosion problems. Ever.

### Stable footing in the wet.

Fielders Expa-Tread™ grate texture means sure foot grip even when the surface is wet. Safer walking in all conditions speeds maintenance work and potentially avoids expensive WorkCover claims.

### Components that comply.

The Fielders Expa Tread™ walkway system has been certified by independent engineers in accordance with AS1657-1992 and AS/NZS 1664.1-1997

### List of components.

- ABRA SAFE Grating Panels 6063-T6 alloy
- 25x40x3mm Aluminium C Section, grade 6063-T6
- Extrusions 1, 2 & 3
- 3M VHB 4991 adhesive tape.

\*When installed by a Fielders approved contractor.

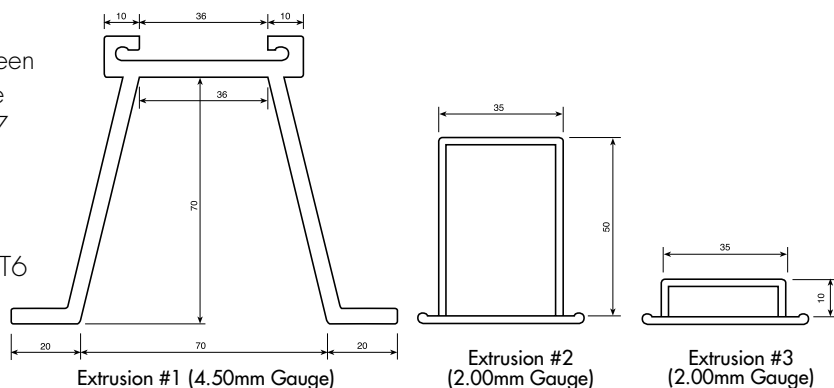

# FIELDERS EXPA-TREAD™

## Get kitted-up and hit the roof.

Fielders Expa-Tread™ is available in kit form, comprising 6 metre lengths of non-slip walkway grating panels 600mm wide plus all necessary brackets and fixing materials. Recommended spacing for supports is 600mm. Fitting is fast and simple. To order, state the number of kits you require as well as how many will run parallel to the ribs of the roof deck and the number of kits that will be at 90 degrees to the rib. A full specification and fitting information pack is supplied with every order.

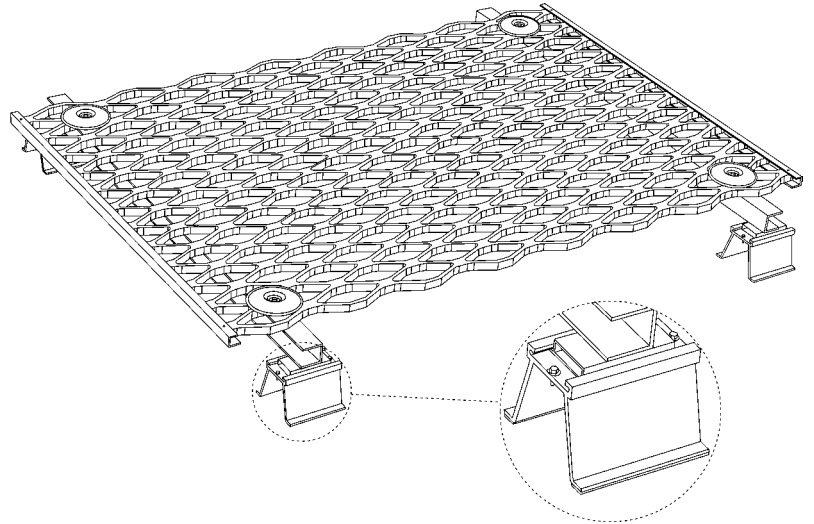

### STEP BY STEP INSTALL

Use a 50% water / 50% Isopropyl Alcohol TT-1-735A (Grade A) mix to clean roof deck (mix prior to going to site). Allow a few seconds, depending on weather conditions before applying fixing bracket.





# Fielders Expa-Tread™ Anything else is a compromise.

Concealed-fix steel roofing is designed as a no-screws, no-leaks commercial solution, so when it comes to fixing walkways, why compromise your standards or your guarantee? Fielders Expa-Tread™ cuts out drilling, screwing and leaks, with the added advantages of being light and corrosion free. It's the premium walkway product that delivers long-term peace of mind with an uncompromised guarantee. So don't screw around with the integrity of your concealed-fix steel roof. Specify Fielders Expa-Tread™.

## Expa-Tread™

So easy to put together Ikea had to have it on the roof of their new Adelaide Airport outlet.



### Other major projects:

- Bianco's new complex at Pooraka
- Palais Apartments Adelaide
- Transend Store Hobart
- Adelaide Zoo, Panda Exhibition
- The Port Lincoln Hotel
- Holdfast Shores Retail Development
- Fairview Park Shopping Centre
- Wine Innovation Central Building



FINISH ON TOP WITH FIELDERS STEEL ROOFING

Phone Fielders First 1800 182 255 [www.fielders.com.au](http://www.fielders.com.au)

ADELAIDE · MELBOURNE · SYDNEY · PERTH · BRISBANE · DARWIN