

2.9 Spanform®

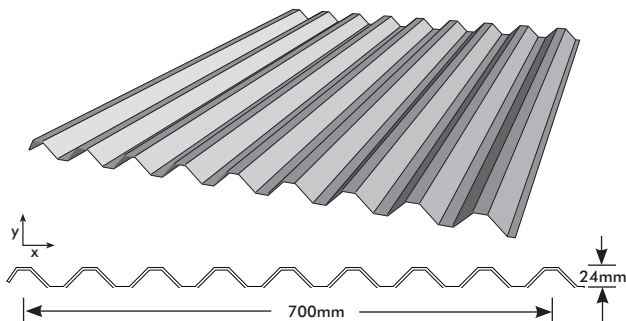

Spanform® WA

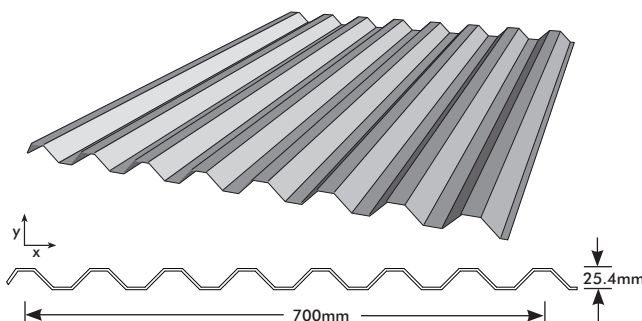

Note: See table 2.9.C Spanform® WA Maximum Recommended Span.

Spanform® Material Specifications				
Property		0.42 BMT	0.48 BMT	Notes
Total Coated Thickness		0.47	0.53	TCT
Mass / Unit Length (kg/m)	ZINCALUME®	3.30	3.70	1000 / (m/Tonne)
	COLORBOND®	3.36	3.77	
Mass / Unit Area (kg/m ²)	ZINCALUME®	4.71	5.29	1000 / (m Mass/profile width)
	COLORBOND®	4.48	5.38	
2 nd moment of area about principal axis (10 ³ mm ⁴)	I _x	35	40	
	I _y	19840	22670	
Section modulus about principal axis (10 ³ mm ³)	Z _x	3	3	
	Z _y	52	59	
Warping Constant (10 ⁹ mm ⁶)	I _w	2	2	
Torsion Constant (mm ⁴)	J	24	35	
Minimum Yield Strength		G300		Base Steel Designation
Coating Class		AZ150		Minimum Coating g/m ² of Zinc - Aluminium
Coverage (mm)		700		
Tolerance		Sheet Length ±7mm Cover Width ±4mm		
Thermal Expansion		2.9mm average per 5m at 50° C change		

Table 2.9.A Spanform® Material Specifications

- Spanform is manufactured to AS 1397 and AS 2728 Cat. 3. It is to be installed in accordance with AS 1445, AS 1562, and HB39.
- The sectional properties are theoretical values per sheet width. These properties are gross values only.

Rainfall Capacity

For further information, please refer to sections 4.2 'Rainfall Intensity' and 4.3 'Water Carrying Capacity and Rainwater Run-Off'.

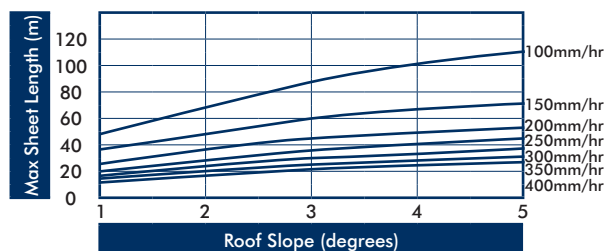

Figure 2.9.A Spanform® Rainfall Capacity (mm/hr)

Note: Minimum recommended slope is 3°. Sheet lengths greater than 24m are not recommended due to thermal expansion and contraction.

Spanform® Maximum Sheet Length (m)							
Roof Slope (degrees)	Rainfall Capacity (mm/hr)						
	100	150	200	250	300	350	400
3	83	55	41	33	28	24	21
4	95	64	48	38	32	27	24
5	107	71	53	43	36	31	27

Table 2.9.B Spanform® Maximum Sheet Length (m)

Load Span Tables

The allowable spans have been determined from tests carried out in accordance with the following Australian Standards (wind load available by region): AS 1562.1 :1992, "Design and installation of sheet roof and wall cladding - Metal" and AS 4040:1992, "Methods of testing sheet roof and wall cladding".

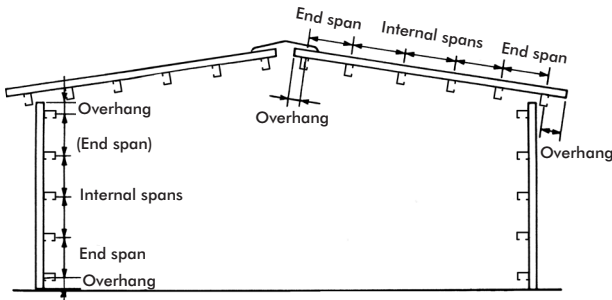

Figure 2.9.B End Spans, Internal Spans and Overhangs

Design Parameters*

Region A:

$h = 10\text{m}$ $C_{p,e} = -0.65$ $P_u = 2.25\text{kPa}$
 $v_u = 50\text{m/s}$ $C_{p,i} = 0.2$ $P_s = 1.93\text{kPa}$
 $K_L = 2.0$

Maximum Recommended Span* (mm) Spanform® WA Non Cyclonic

Span Type	0.42 BMT		0.48 BMT	
	Roof	Wall	Roof	Wall
Single Span	1800	2000	2100	2050
End Span	1800	2350	2200	2500
Internal Span	2250	2900	2800	3100
Unstiffened Overhang	250	300	250	300
Stiffened Overhang	500	300	500	300

Table 2.9.E Spanform® WA Maximum Recommended Span - Non Cyclonic

Maximum Recommended Span* (mm) Spanform® Non Cyclonic

Span Type	0.42 BMT		0.48 BMT	
	Roof	Wall	Roof	Wall
Single Span	1300	1800	2000	2600
End Span	1800	1800	2200	1900
Internal Span	2400	2700	3000	2800
Unstiffened Overhang	250	300	250	300
Stiffened Overhang	500	300	500	300

Table 2.9.F Spanform® Maximum Recommended Span - Non Cyclonic

Spanform® Pierce Fixing - Non Cyclonic

Fixing Supports	Crest Fixing	Valley Fixing (Wall only)	Side Lap Fixing
Steel 1.0 to 3.5mm	M5.5 x 50mm Auto Tek's hexagon head with HiGrip & seal	10-16x16mm Metal Tek's hexagon head with seal	10-16x16mm hexagon head Tek's screws with seal
Timber Hardwood	M6-11x65mm RoofZips hexagon head with HiGrip & seal	M6-11x25mm RoofZips hexagon head with seal	
Timber Softwood	M6-11x65mm RoofZips hexagon head with HiGrip & seal	M6-11x25mm RoofZips hexagon head with seal	
Metal Battens (0.55 to 1.0mm)	M6-11x50mm RoofZips hexagon head with HiGrip & seal	15-15x25mm Metal Batten Tek's hexagon head with seal	

Table 2.9.C Spanform® Pierce Fixing - Non Cyclonic

Spanform® Pierce Fixing - Cyclonic

Fixing Supports	Crest Fixing	Valley Fixing (Wall Only)	Side Lap Fixing
Steel 1.0 to 3.5mm	14-10x50mm Metal Tek's hexagon head with Square-Lok cyclone assembly	14-10x25mm Metal Tek's hexagon head Ext Pt/Seal	10x16mm hexagon head Neo Tek's
Timber Hardwood	14-10x65mm Type 17 hexagon head with Square-Lok cyclone assembly	14-10x25mm Type 17 hexagon head with seal	
Timber Softwood	14-10x75mm Type 17 hexagon head with Square-Lok cyclone assembly	14-10x25mm Type 17 hexagon head with seal	
Metal Battens (0.55 to 1.0mm)	15-15x55mm Metal Batten Tek's hexagon head with Square-lok cyclone assembly	15-15x25mm Metal Batten Tek's hexagon head with seal	

Table 2.9.D Spanform® Pierce Fixing - Cyclonic

Pierce Fixing

Fasteners must be selected to match the life expectancy of the cladding material. Recommendations from fastener manufacturers should be sought.

Only fasteners complying with AS 3566:2002 and those that are compatible with the roofing material should be used for its fastening.

Notes: All fasteners used externally should be fitted with an EPDM seal (washer).
Do not use punches to form fastener holes.

AQUABLOK™ System

The AQUABLOK system utilises an anti-capillary gap that prevents water from seeping into roofing joints.

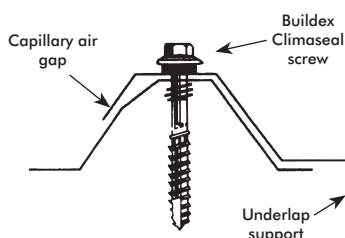

Figure 2.9.C AQUABLOK™ System

Side Lap Fixing

Side lap fasteners may be necessary at mid spans for purlin spacings over 900mm and girt spacings over 1200mm to hold the sheet laps firmly in place and maintain a weather-proof joint. Use 10-12 x 20mm Needle point hexagon head self-drilling stitching screws.

Note: Do not use punches to form fastener holes.

Fastener Spacings - Non Cyclonic	
Crest Fastener Location	
	4 Fasteners per sheet – end supports and end laps
	3 Fasteners per sheet – Internal supports Roofing should be lapped away from the prevailing weather.
Valley Fastener Location (Wall Only)	
	4 Fasteners per sheet – end supports and end laps
	3 Fasteners per sheet – Internal supports

Table 2.9.G Spanform® Fastener Spacings - Non Cyclonic

Spanform® Installation Procedure

For installation procedures see section 4.7 "Typical Pierce Fix Installation Guide". For general handling instructions refer to section 5.0 'Maintenance and Care'.

Turning of Roof Sheeting Ends

Refer to section 4.8 "Flashings, Cappings & Ends of sheets".

Curving

For details regarding spring and crank curving of Spanform sheets, please see section 4.5 "Curving of Steel Decks".

Spanform® Flashings & Details			
Masonry Parapet Side Wall (Low) Product Code: SF1	Masonry Parapet Side Wall (High) Product Code: SF2	Apron Flashings Product Code: SF3 GIRTH 300	Overflashing Product Code: SF4 Girth 112
Headwall Apron Flashing Product Code: SF5 Girth 300	Soaker Gutter Product Code: SF6 Girth 350	Soffit Corner Flashing Product Code: SF7 Girth 149	Shoe Flashing Product Code: SF8
Offset Wall Flashing Type 1 Product Code: SF9 GIRTH 150	Offset Wall Flashing Type 2 Product Code: SF10	Valley Gutter Product Code: SF11 Girth 324	Under Over Flashing Product Code: SF12 Girth 300
Mansard Roof Flashing Product Code: SF13 Girth 330	Industrial Door Jamb Flashing Product Code: SF14 Girth 150	Opening Jamb Flashing Product Code: SF15	Door Head Flashing Product Code: SF16 Girth 100
Apex Capping Type 1 Product Code: SF17 Girth 290	Apex Capping Type 2 Product Code: SF18 Girth 270	Back Channel Product Code: SF19 Girth 110	External Corner & Barge Capping Product Code: SF20 Girth 330
Internal Corner Capping Product Code: SF21 GIRTH 330	Barge Capping Product Code: SF22 GIRTH 255	Fragmented Parapet Capping Product Code: SF23	Two Piece Step Flashing Product Code: SF24

Table 2.9.H Spanform® Flashings & Details

1. ★ denotes size to be determined by application. All sizes are in mm and should be used as a guide only. They should be measured on-site to determine actual size.

2. S.B. denotes 'Slight Break'.
 3. Also refer to section 4.6 "Typical Roofing Details".